

Important: Read all instructions prior to installation.

CCED-20W-1555-96CHX-FC

Constant Current Emergency LED Driver



Specifications

Model	CCED-20W-1555-96CHX-FC
IP Rating	IP30
Operating Temperature	32°–131° F (0°–55° C)
Emergency Operation Duration	90 minute (minimum)

Check product label for specific electrical specifications related to installation.
Improper installation will void warranty.

Safety and Notes

READ AND FOLLOW ALL SAFETY INSTRUCTIONS

- Do not join battery connector or turn “ON” the battery switch until installation is complete and AC power is supplied to the emergency driver.
- This product is intended for use with an emergency LED lighting load and supplies nominal of power and a maximum voltage in emergency mode for a minimum of 90 minutes.
- An unswitched AC power source is required (120-277 VAC 50/60 Hz) to power these units.
- This product’s chassis must be grounded.
- This product is suitable for use in damp locations where the ambient temperature is 0° C minimum, to 55° C maximum. This product is also suitable for installation in sealed and gasketed fixture. This product is not suitable for heated air outlets and wet or hazardous locations. Maximum allowable case temp is 70° C. Refer to the below image for TC measurement location.
- This product contains a rechargeable LiFePO4 battery. The battery must be recycled or disposed of properly.
- Make certain all connectors are in accordance with the National Electrical Codes and any local regulations.
- This emergency LED driver is suitable for both factory or field installation. For field installation, please see the instructions on page 3.
- Do not install near gas or electric heaters.
- The use of accessory equipment is not recommended by the manufacturer and may cause an unsafe condition.
- Do not use this product for applications other than the intended use.
- Equipment should be mounted in locations and at heights where it will not be subjected to tampering by unauthorized personnel.
- This device complies with part 15 of the FCC Rules. Operation is suitable to the following two conditions: (1) This device may not cause harmful interference, and (2) This device must accept any interference that may cause undesired operation.
- To reduce the risk of electric shock, disconnect both normal and emergency power supplies and place the battery switch in the “OFF” or disconnect the battery connector of the emergency driver before servicing.
- Do not attempt to service the battery. It is a sealed, no-maintenance battery that is not field replaceable. Contact the manufacturer for information on service.
- Service should be performed by qualified service personnel only.
- Emergency driver and standard driver must be on the same branch circuit.
- Driver output is Class 2 at the intended output voltage range.

Testing

Manual Test

Test button can be held for manual testing purposes.

Note: A short-term discharge test may be conducted after the emergency driver has been charged for one hour. A 48-hour charging period must be required before conducting a long-term discharge test.

TC Case Test Point Location

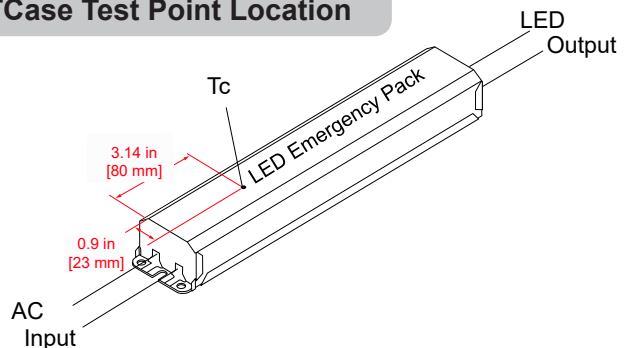

Important: Read all instructions prior to installation.

Constant Current Emergency LED Driver

Installation Checks

Before installation, make sure the necessary branch circuit wiring is available. An unswitched source of power is required. The emergency driver must be fed from the same branch circuit as the AC driver. This product is suitable for field installation with suitable LED loads. There are three checks to determine if your luminaire is eligible for field installation.

- The LED load's rated power must be greater than or equal to the power output of the emergency LED driver to ensure that the LED load will not be damaged when the system is in emergency mode.
- Verify that the forward voltage of the luminaire's LED array is within the limits of the emergency LED driver. The forward voltage of the LED array is commonly designated as Vf and should be found on the luminaire, in the luminaire specifications, or imprinted directly on the LED arrays. If multiple LED arrays are to be driven, verify that the total forward voltage is within the limits of the emergency driver.
- Ensure the output current of the LED driver does not exceed 8 amps. This is the current into the red/blue output wire.

Mounting Height and Remote Mounting

This product meets or exceeds the NFPA minimum light requirements with all loads, down to the smallest rated lamp load, at heights up to 7.17 ft (2.2 m). For field installations, when the attached luminaire is mounted at heights greater than 7.17 ft (2.2 m), the level of illumination must be measured in the end application to ensure the requirements of NFPA 101 and local codes are satisfied.

Note: After installation, it will be necessary to measure the egress lighting illumination level to ensure it complies with national state and local code requirement.

The emergency LED driver may be remote mounted a short distance from the luminaire. If used in conjunction with an external driver, the allowed distance is up to half the distance the driver manufacturer recommends remote mounting the driver from the LED load. If used with a luminaire with integrated driver, remote mounting 18 ft or less from the luminaire.

CAUTION: Remote mounting can result in reduced power output. Correct wire gauge must be used as determined by installation details.

Wiring Diagram

EMERGENCY DRIVER AND AC DRIVER MUST BE FED FROM THE SAME BRANCH CIRCUIT TYPICALLY. IT MAY BE USED WITH OTHER DRIVERS IF OUTPUT IS SUFFICIENT.

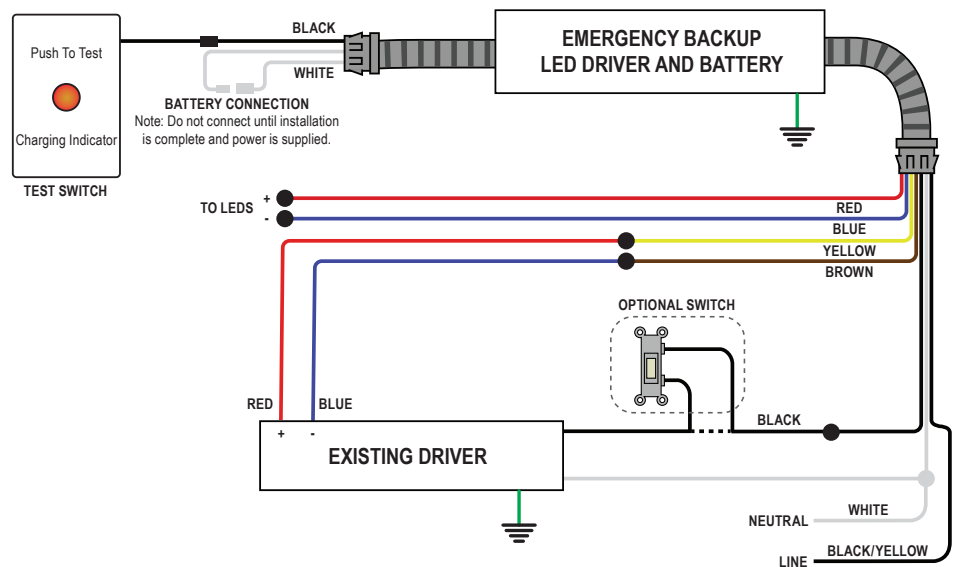

Important: Read all instructions prior to installation.

Constant Current Emergency LED Driver

Installation

CAUTION: DO NOT JOIN BATTERY CONNECTOR OR ACTIVE BATTERY SWITCH UNTIL INSTALLATION IS COMPLETE AND AC POWER IS SUPPLIED TO THE EMERGENCY DRIVER.

1. Disconnect AC power from the LED luminaire/driver.
2. Mount the emergency LED driver by the mounting tabs using appropriate screws (not provided).

Note: If the application requires the emergency LED driver to be mounted on top of the luminaire, flexible metal conduit should be used over wiring.

3. Mount the supplied illuminated test switch in a location that is visible and accessible by maintenance personnel. The switch mounts through a hole which will need to be added to the luminaire or nearby structure. Wire the test switch according to the wiring diagram. If wired correctly, the test switch indicator light should be on when AC power is supplied to the fixture, and the battery switch is on indicating that the emergency inverter battery is charging.

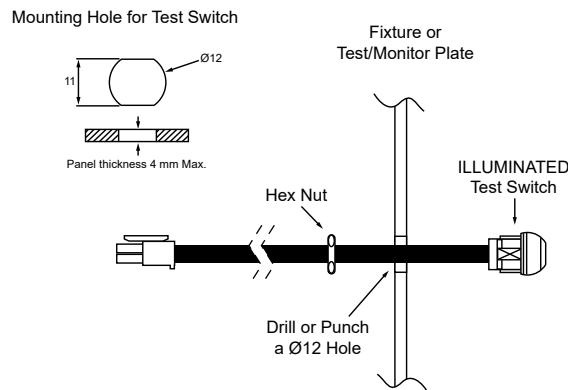

4. Connect the emergency driver to the AC driver and LED load according to wiring diagram. Make sure all connections are in accordance with the National Electrical Code and any local regulations. After installation is complete, supply AC power to the emergency driver and turn on battery switch/join battery connector. At this point, power should be connected to both the AC driver and the emergency driver, and the charging indicator light should illuminate indicating the battery is charging.

Maintenance

REFER ANY SERVICING NEEDS INDICATED BY THESE CHECKS TO QUALIFIED PERSONNEL.

CAUTION—This unit has more than one power connection point. To reduce the risk of electric shock, disconnect both the branch circuit breakers or fuses and emergency power supplies before servicing.

Although no routine maintenance is required to keep the emergency driver functional, it should be checked periodically to ensure that it is working. The following schedule is recommended:

1. Visually inspect the charging indicator light monthly. It should be illuminated. If the charging indicator is off. Contact tech support.
2. Test the emergency operation of the fixture at 30-day intervals for a minimum of 30 seconds. The LED load should operate at reduced illumination.
3. Conduct a 90-minute discharge test once a year. The LED load should operate at reduced illumination for at least 90 minutes.

Important: Read all instructions prior to installation.

Constant Current Emergency LED Driver

Operation

During normal operation AC power is applied to the driver and the charging indicator light is illuminated, which indicates that the battery is being charged. When power fails the emergency LED driver will automatically switch to emergency power (internal battery), operating the LED load for a minimum of 90 minutes. When AC power is restored, the emergency driver returns to charging mode.

Hipot Test

CAUTION: PLEASE FOLLOW THE WIRING DIAGRAM BEFORE DOING HIPOT TEST, OTHERWISE IT MIGHT CAUSE DAMAGE TO THE EMERGENCY DRIVER OR AC DRIVER.

There are two different scenarios for performing hipot test—with an AC driver or without an AC driver. Wiring diagrams for both scenarios are provided below. Please follow the wiring diagram before performing hipot testing. The recommend setting is 1.5 kV, 5 mA/1 sec.

Hipot with AC Driver

Short all three input wires (white, yellow/black and black) together. Also, if an optional wall switch is being used ensure wall switch is “ON”. At this point, it should be safe to begin hipot testing.

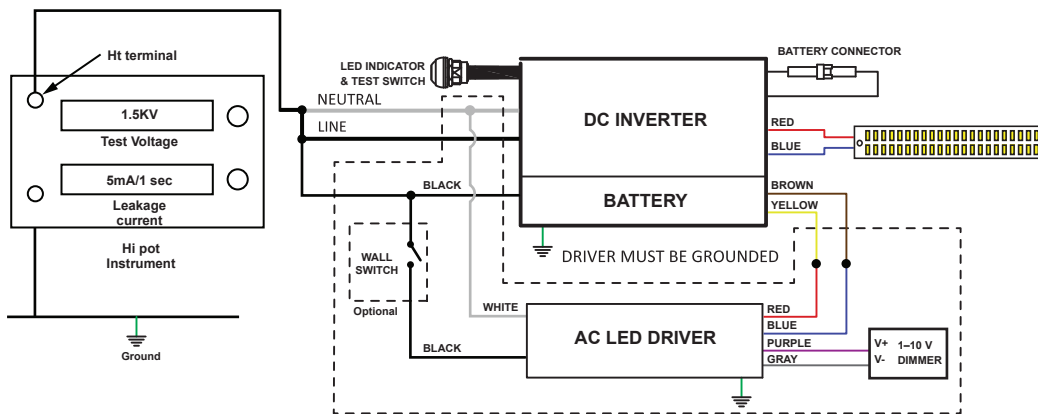

Hipot without AC Driver

Short two input wires (white and yellow/black) and cap off battery output (black) wire to leave that circuit open. At this point, it should be safe to begin hipot testing.

