

Important: Read all instructions prior to installation.

Wireless LED Dimmer Wall Switch for EZ Dimmer Series Controllers

Parts Included

- 1 - 868MHz LED Dimmer Wall Switch
- 1 - 3V CR2032 Battery with Tray
- 2 - Mounting Screws

Wall Switch

1 On/Off/Brightness Push Dial

Press dial for remotely activating/controlling light strips.

Dial Actions:

Single Press	Turns light on/off. If the Controller Pairing Switch has been depressed, a single dial press on the Wall Switch pairs the Switch to the Controller
Left / Right Rotate	Dimming Mode: Controls LED intensity level.
Hold Press	Increases LEDs to maximum intensity

2 Dimming Level

Visual key representing the dial intensity level.

Controller

3 Pairing Switch

To pair Wall Switch to Controller, press the Controller pairing switch once and then press Wall Switch dial. Lights will blink once to indicate pairing. To unpair Wall Switch(es), press and hold Controller Pairing Switch until lights blink twice.

4 Master/Slave Jumper

Set Jumper to Master for main Controller. Master emits synchronization signal to Slave Controllers. Set Jumper to Slave to receive synchronization signal from Master Controller. Use Master for the first Controller in each zone. To achieve precise synchronization between Controllers in one zone, set additional Controllers to slave.

Wall Switch Installation Steps

1. Pull off dial and collar from front plate.
2. Using a flat head screwdriver, pry rear switch housing away from front plate.
3. Insert battery with tray into slot, matching the polarity on the battery with the slot labels.
4. Fasten wall switch using mounting screws.
5. Reinstall front plate, collar and dial.

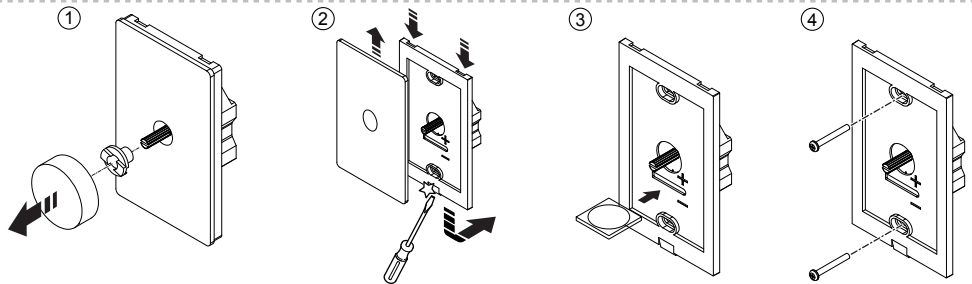

Cove Lighting Application

Operating the Wall Switch/Controller

1. Press "Pairing Switch" button on the Controller. Immediately press the dial on the Wall Switch to pair it to the Controller. The LED lights wired to the Controller will blink when the pairing is complete.
2. Multiple Wall Switches can be paired to a Controller, and Wall Switches can be paired to multiple Controllers. If multiple Controllers paired to a Wall Switch are not in sync, unpair and then pair until Controllers and lights are in sync.

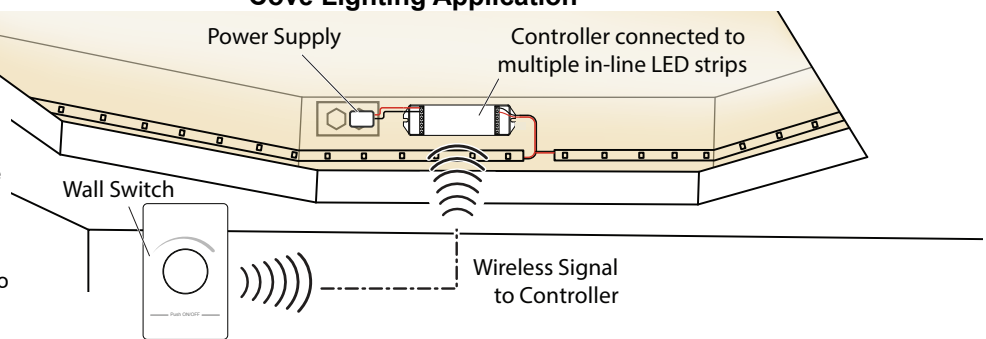

EZD-1C-WM Wall Switch

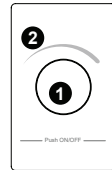

EZD-1C8A Controller

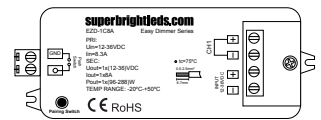

EZD-1C-WM Wall Switch	
Operating Voltage	3 VDC
Battery Size	CR2032
Operating Frequency	868 MHz
FCC ID#	2ACUQ2836

EZD-4C8A Controller

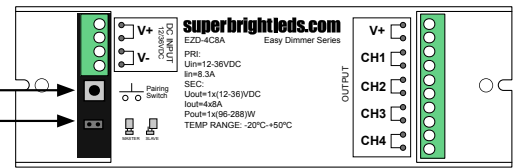

EZD-4C8A Controller		
Input Voltage	Current	Output Wattage
12-36 VDC	4 X 8A	384W(12V) 768W(24V) 1152W(36V)

EZD-1C8A Controller		
Input Voltage	Current	Output Wattage
12-36VDC	1 X 8A	96W(12V) 192W(24V) 288(36V)

FCC Statement

This device complies with part 15 of the FCC Rules. Operation is subject to the following two conditions: (1) This device may not cause harmful interference, and (2) This device must accept any interference received, including interference that may cause undesired operation. Any changes or modifications in construction of this device which are not expressly approved by the party responsible for compliance could void the user's authority to operate the equipment.

Set-Up Instructions

Wall Switch

1. Follow illustrated steps below to remove the Battery Tray. Insert the 3V battery included with the Wall Switch.

Controller

1. Make sure power to the Controller is disconnected.
2. Using a small flathead screwdriver, loosen the labeled terminal screws visible on the top of the Controller.
3. Matching light strip wires with labeled slots on the Controller, insert wires and tighten terminal screws. Be sure wire conductor, not wire insulation, is secured in terminal.
4. Turn power on and wait until light strip illuminates. If it does not come on, check light strips and wiring connections.

Safety

- DO NOT install with power applied to Controller.
- DO NOT expose the Wall Switch or Controller to moisture.



Important: Read all instructions prior to installation.

Wireless LED Dimmer Wall Switch for EZ Dimmer Series Controllers

Connection Diagram

EZD-4C8A Controller

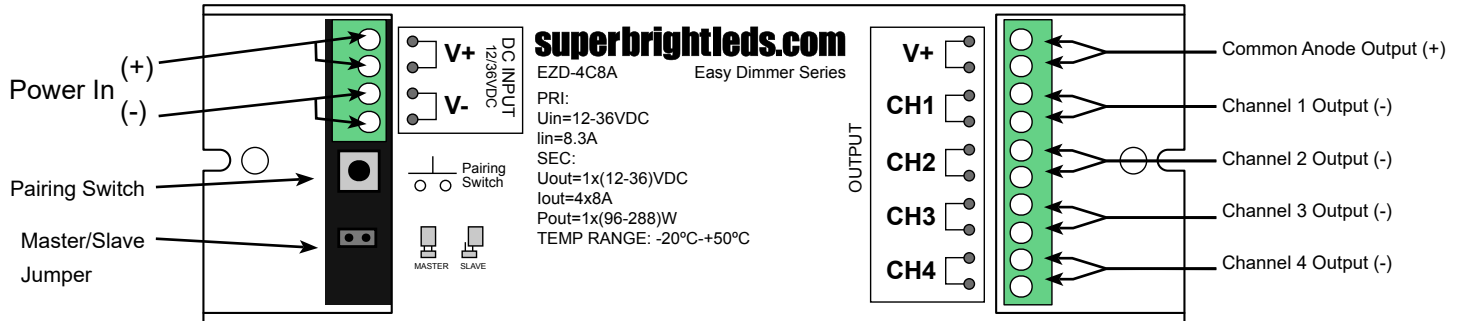

EZD-1C8A Controller

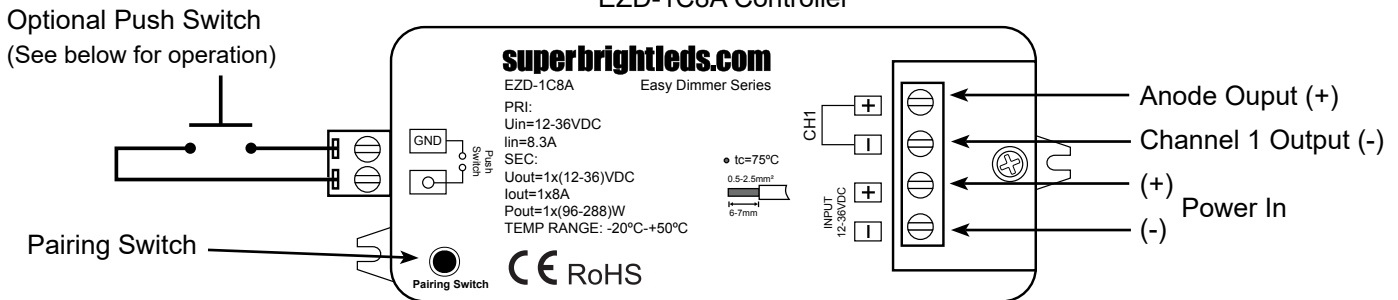

Example Diagrams

(1) Single Color 24VDC Application / EZD-4C8A

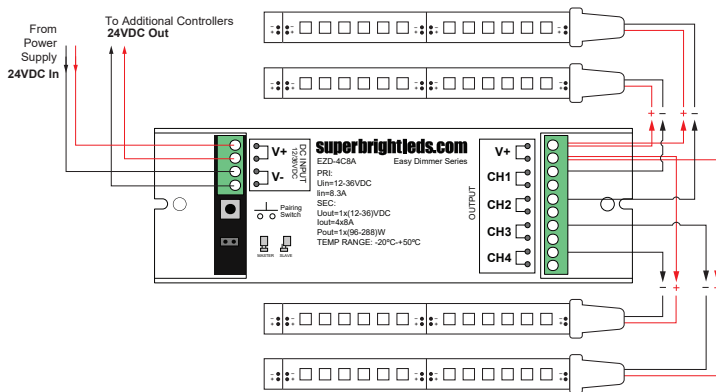

(2) Four Color 12VDC Application / EZD-4C8A

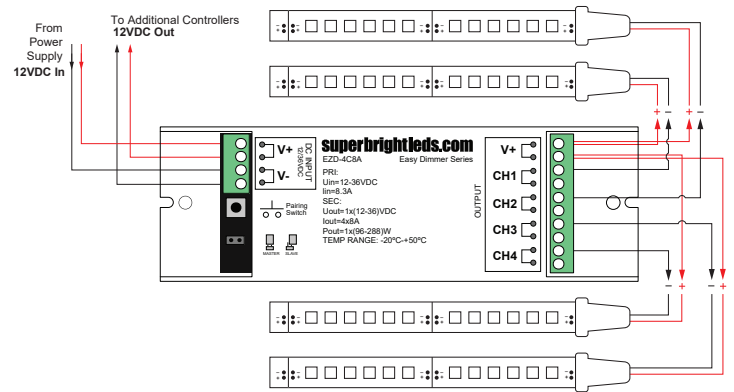

(3) Single Color 12VDC Application / EZD-1C8A

