

## **SPECIFICATION FOR APPROVAL**

- ★ **Commodity: 5050 SMD**
- ★ **Model No: 5050-RGB**
- ★ **Emission Color: RGB**
- ★ **Lens Appearance: Water Clear**
- ★ **Quality & Safety Certification: RoHS**

<b>CUSTOMER APPROVED BY</b>	<b>DATE</b>

## ● Package Dimensions

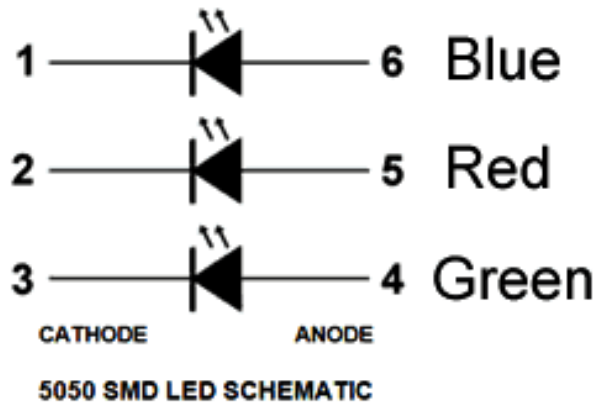
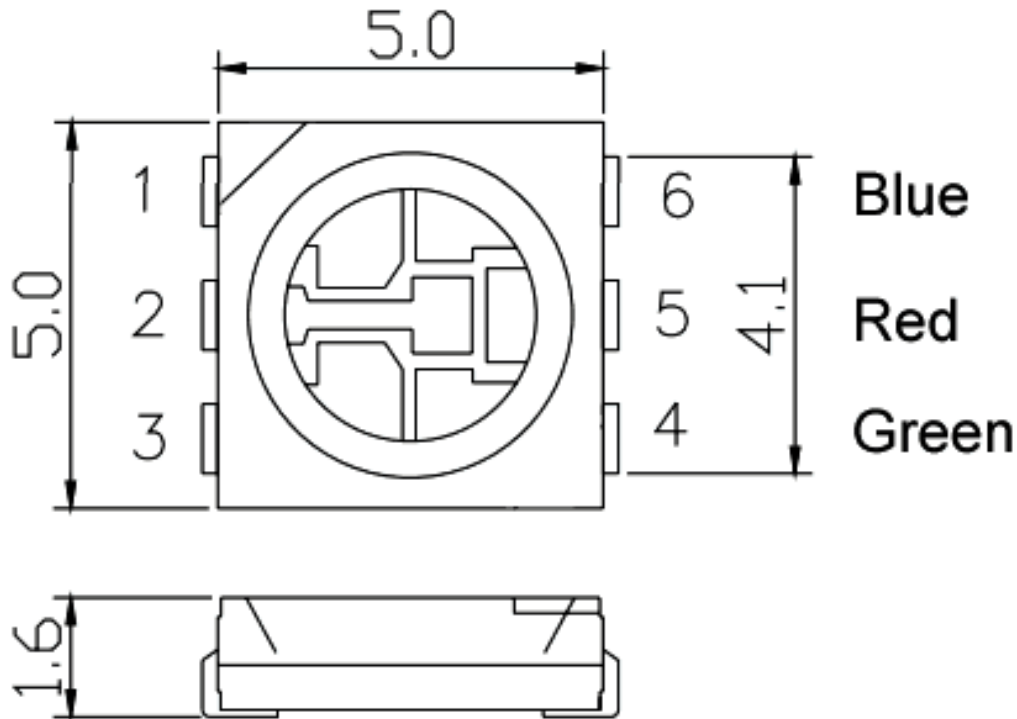

### Notes

- 1: All dimensions are in millimeters.
- 2: Tolerance is  $\pm 0.1$  mm unless otherwise specified.

● Absolute Maximum Ratings ( $T_a = 25^\circ\text{C}$ )

Parameter	Symbol	Rating	Unit
Power Dissipation	$P_d$	R:100 G:100 B:100	mW
Forward Current	$I_F$	R:20 G:20 B:20	mA
Peak Forward Current* <sup>1</sup>	$I_{FP}$	R:100 G:100 B:100	mA
Reverse Voltage	$V_R$	R:5 G:5 B:5	V
Operating Temperature Range	$T_{opr}$	-20~80	$^\circ\text{C}$
Storage Temperature Range	$T_{stg}$	-40~85	$^\circ\text{C}$
Soldering Temperature	$T_{sol}$	260 (for 5 seconds)	$^\circ\text{C}$

● Typical Electrical-Optical Characteristics Curves ( $T_a=25^\circ\text{C}$ )

Parameter	Symbol	Condition	Min	Typ	Max	Unit
Forward Voltage	$V_F$	R	1.8	2.0	2.2	V
		G	3.0	3.2	3.4	V
		B	3.0	3.2	3.4	V
Reverse Current	$I_R$	$V_R = 5V$			10	$\mu\text{A}$
Dominant Wavelength	$\lambda_D$	R	620	625	630	nm
		G	515	520	525	nm
		B	460	465	470	nm
Luminous Intensity	$I_v$	R	500	650	800	mcd
		G	800	1000	1200	mcd
		B	300	400	500	mcd
Viewing Angle	$2\theta_{1/2}$	$I_F = 20\text{mA}$		120		deg

● Typical Electrical/Optical Characteristics Curves (R)

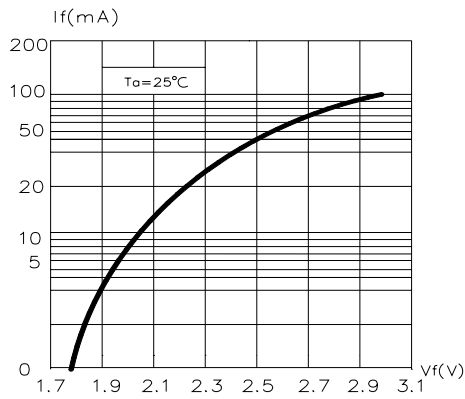

Fig.1 Forward Current vs. Forward Voltage

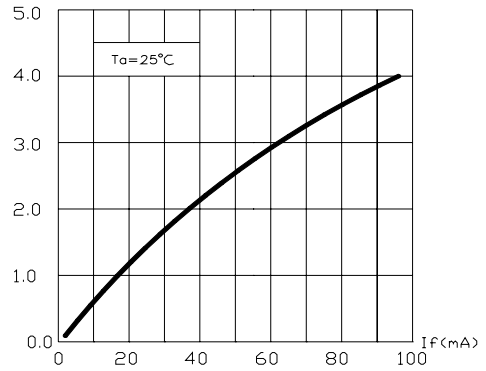

Fig.2 Relative Luminous Intensity vs. Forward Current

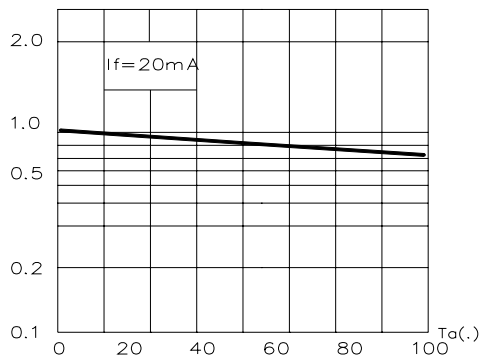

Fig.3 Relative Luminous Intensity vs. Ambient Temperature

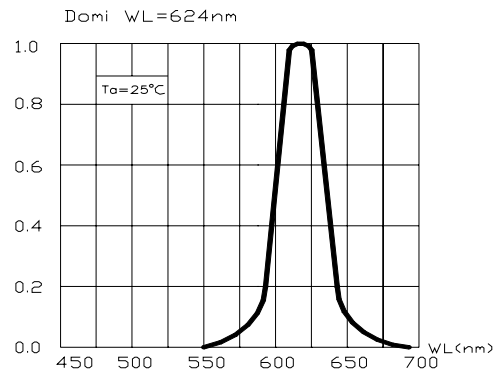

Fig.4 Relative Luminous Flux vs. Wavelength

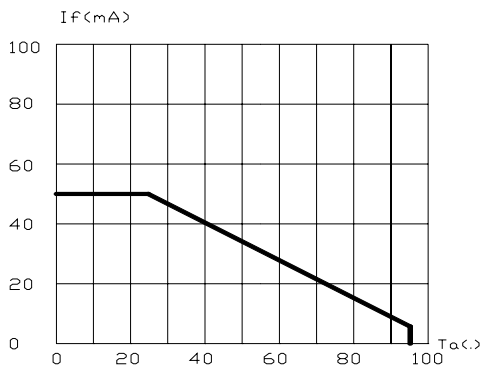

Fig.5 Maximum Forward Current vs. Ambient Temperature

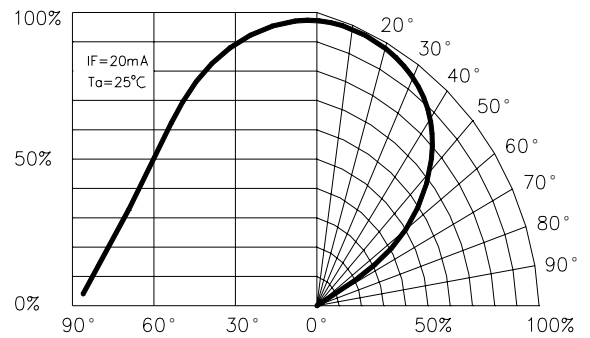

Fig.6 Relative Luminous Intensity vs. Radiation Angle

● Typical Electrical/Optical Characteristics Curves (G)

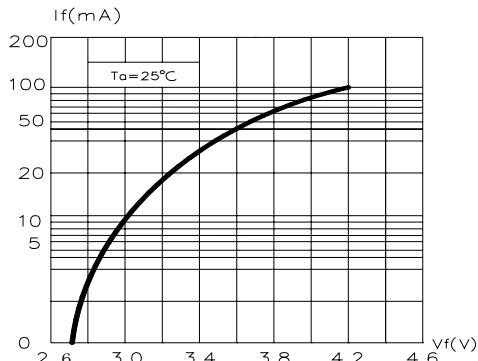

Fig.1 Forward Current vs. Forward Voltage

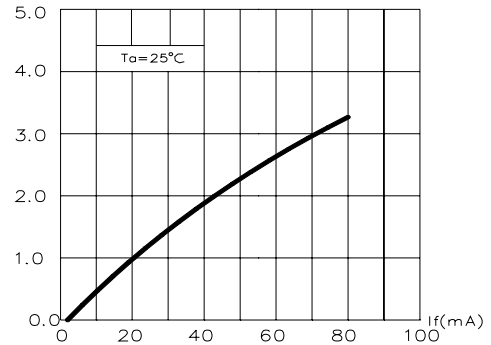

Fig.2 Relative Luminous Intensity vs. Forward Current

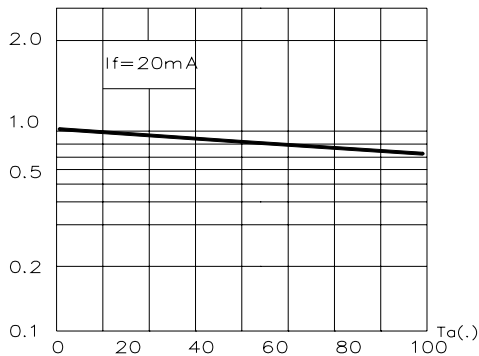

Fig.3 Relative Luminous Intensity vs. Ambient Temperature

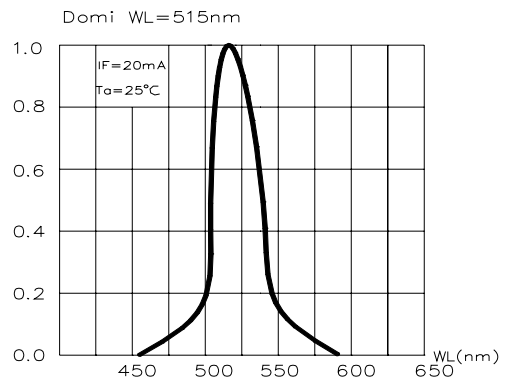

Fig.4 Relative Luminous Flux vs. Wavelength

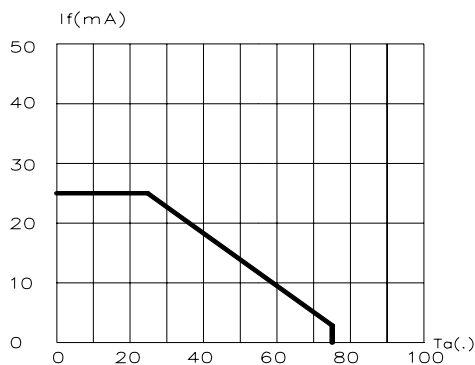

Fig.5 Maximum Forward Current vs. Ambient Temperature

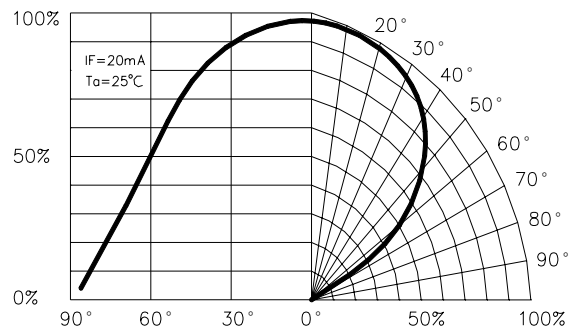

Fig.6 Relative Luminous Intensity vs. Radiation Angle

● Typical Electrical/Optical Characteristics Curves (B)

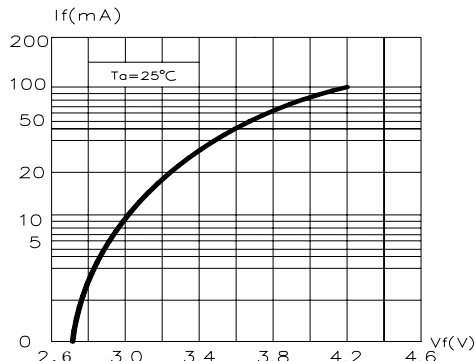

Fig.1 Forward Current vs. Forward Voltage

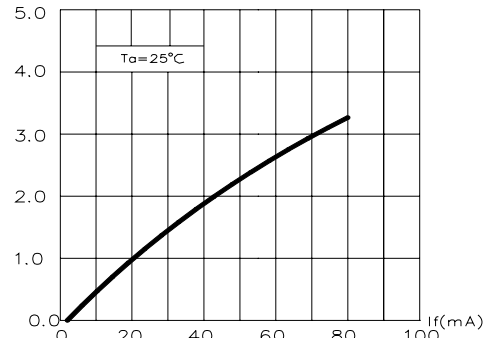

Fig.2 Relative Luminous Intensity vs. Forward Current

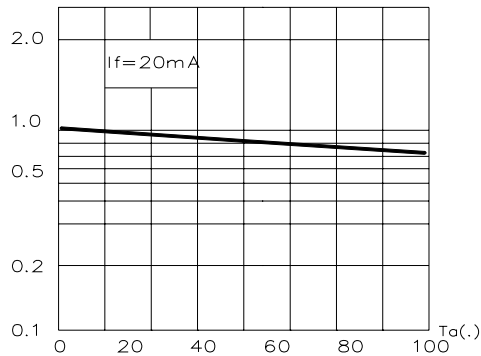

Fig.3 Relative Luminous Intensity vs. Ambient Temperature

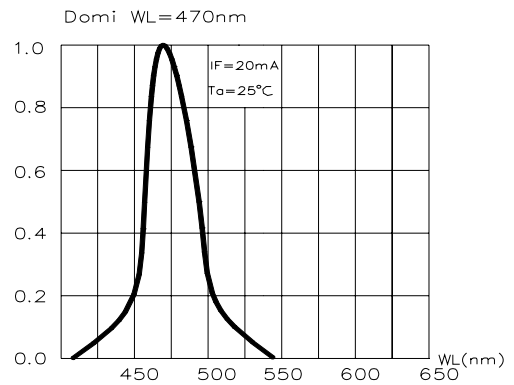

Fig.4 Relative Luminous Flux vs. Wavelength

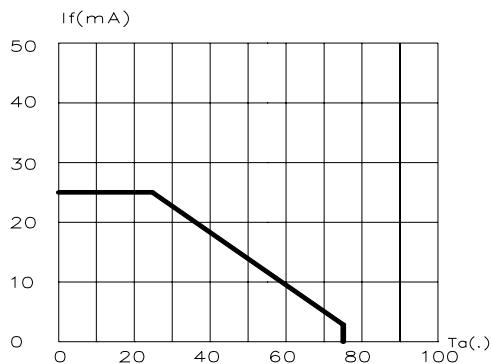

Fig.5 Maximum Forward Current vs. Ambient Temperature

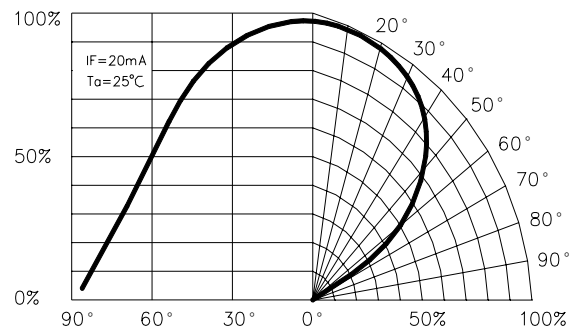

Fig.6 Relative Luminous Intensity vs. Radiation Angle